

# Precision capacitance meter

Francesc Casanellas - October 22, 2013

This Design Idea presents a very accurate, yet very inexpensive, capacitance meter. It was specifically designed for measurements of low value capacitance - with an accuracy of better than 1pF - for a gasoline capacitive level gauge, but it can be used in any range of capacitance by modifying component values. Because the aim was to use it in gasoline level gauges, the power supply part is designed to withstand the voltage transients expected in a motorbike or automotive power supply.

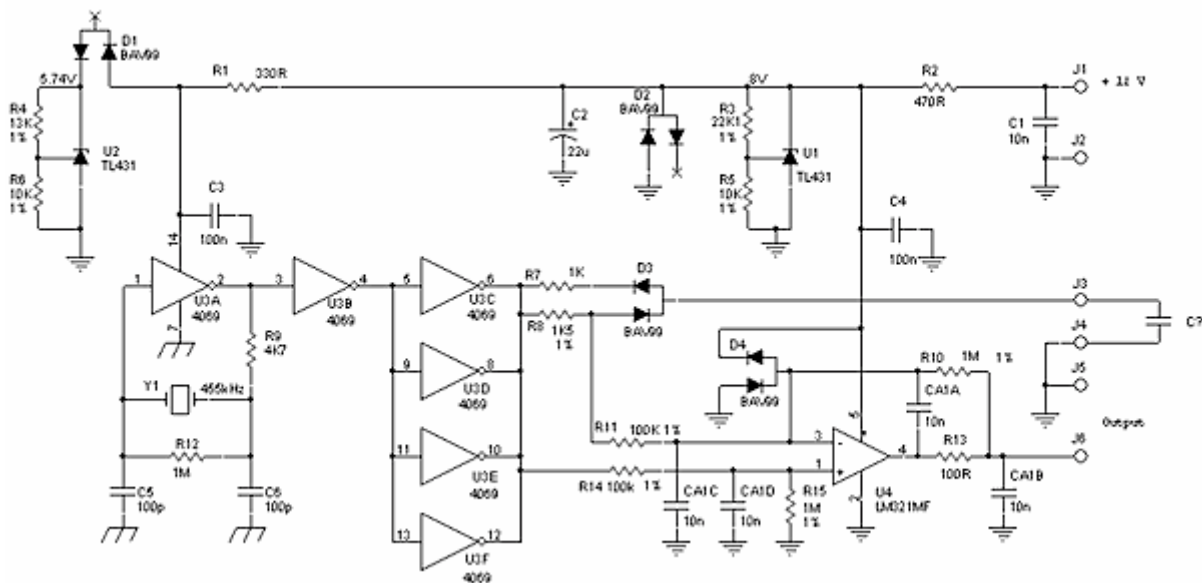
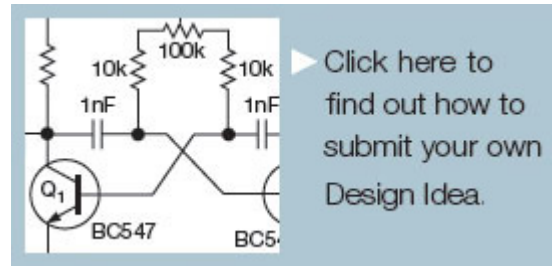

U3A is an oscillator using the ceramic resonator Y1. The output of U3C to U3F charges and discharges the capacitor to be measured at a 455kHz rate. The charge current flows through R8, and it is filtered and amplified by the differential amplifier U4. The discharge is made through D3. The average current in R8 is proportional to the capacitance.



The voltage that charges the capacitor is the one set in U2 - 5.74V - plus the drops in D1. The voltage drops in D1 are temperature dependent, so it compensates exactly the temperature variation in D3.

For 5V output, if  $A_v$  is the amplifier gain, the maximum capacitance to be measured is:

$$C = 5V / (5.74V \cdot A_v \cdot R8 \cdot 455,000Hz)$$

In this case,  $A_v = 10$ , so  $C = 128\text{pF}$ . For lower values, simply increase the value of R8.

The capacitor being measured has to be fully charged and discharged, but to measure high value capacitors, R8 cannot be decreased too much. The best way is to decrease the frequency - for example, using a 4060, and selecting the appropriate output. Then, the fine adjustment may be done by R8 and/or the amplifier gain.

**Also see:**

- [Build your own capacitance meter](#)
- [Capacitance meter uses PLL for high accuracy](#)
- [VFC makes simple capacitance meter](#)
- [Digital timer has independent on/off period](#)